

Installing the DIY Shade Sail

Thank you for purchasing a Shaded Nation **DIY Shade**.

We hope this product will assist you in creating a functional and visually appealing outdoor entertaining area, and importantly protect you, your family, and your visiting friends from the harsher aspects of the summer sun. To determine positioning of your fixings, take the sail out from its packaging, and lay it flat on the ground in the area where it is being installed.

Once your sail is laid out and in position, allow approximately 300mm (1ft) **DIAGONALLY** from each corner for placement of your posts/fixings. Remember, it does not hurt to leave more space between the post and the sail, as this can be accommodated by a larger turnbuckle or even rope if required, however if the space is too small then inadequate tension will be able to be maintained through the sail, it will sag, its quality will be compromised, and it certainly would not look as good as perhaps it could have.

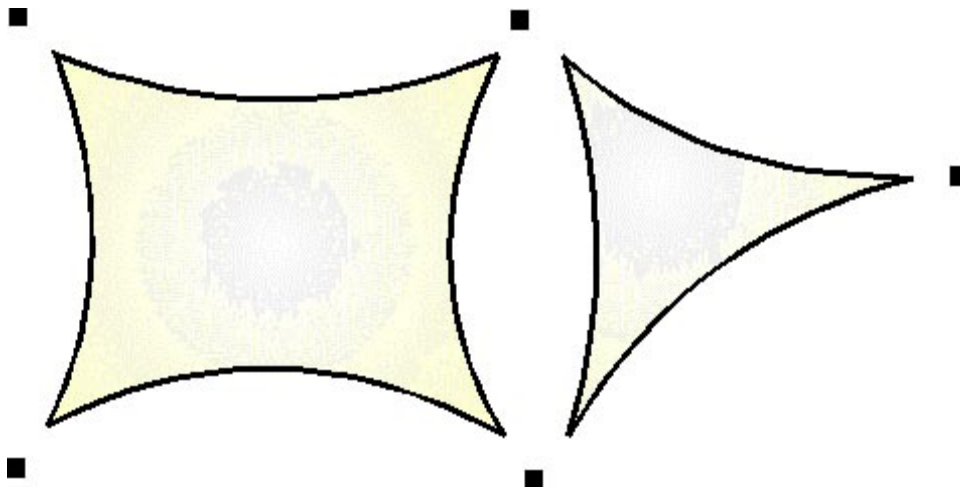

Irrespective of whether your sail is triangular or square, always allow plenty of distance from your sail to the fixing point, and attempt to make the directional pull from the fixing point to the sail diagonal.

You can select the relevant tensioning accessories for fixing the sail to your fixings once you have considered the following:

A Word about Fixings

Caution is imperative when considering fixing to existing structures, such as your house. In instances of poor weather and strong winds, the loads placed on fixings by the sail are enormous, and should not be underestimated.

For the best safety practises, you should remove your sail when high wind conditions are forecast.

We recommend you use steel or aluminium posts, and not timber posts, for your sail structure, with a minimum size of 100mm x 100mm (4") (square) or 100mm (4") diameter (round), and a 4mm (1/6") wall thickness. This should be increased where the column is longer than 3.6m (12ft) out of the ground. Steel is stronger than timber, will not overly deflect as noticeably (bend from the ground up), and will not rot. Rust factors can be compensated by using galvanised steel or aluminium. Note that steel is inherently stronger than aluminium, and thus is typically cheaper to obtain, however this does vary from country to country.

Where timber posts are appropriate, such as for temporary use of the sail shade, use a minimum diameter of 125mm (5") (or 125mm x 125mm square).

Required footing sizes for columns vary, depending on the size of the structure and the height of the post out of the ground. An old conservative engineering principal is "1 third in, 2 thirds out", which means posts out of the ground by 2400mm (8ft) need to be at least 1200mm (4ft) into the ground. This is typically considered conservative; however we recommend you strongly consider this principal, as correcting a post that has been leant over in high winds due to an undersized footing is a difficult, sometimes impossible, job. Even a small movement of your footing will also compromise the ability to tension the sail, thus reducing the likelihood of maximum longevity. If you are digging through land fill or raised garden beds, these depths should not be included in the overall depth of the footing. An ideal situation follows:

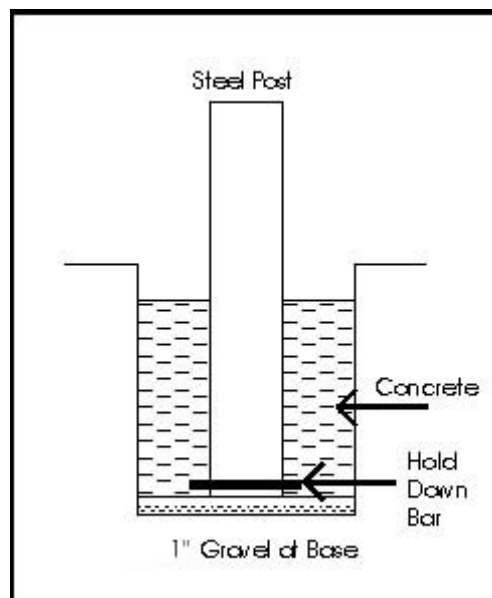

As a general rule, hole diameters should be around 350mm (1'2"), however increasing as column sizes increase. Depth, however, is the most important factor.

Ensure your area is clear of underground services, such as sewage and water plumbing, or electrical cabling, prior to digging holes for your footings. Damages to services can be dangerous, and expensive to correct. Consider a services search prior to digging if you do not have plans of underground services available.

You should also check with your local authorities as to relevant building regulations that may be a factor in your development of a Sail Shade structure.

When you are happy with the positioning of your fixings, install as required. You should install your sail once any installed footings have fully set, in accordance with the steps mentioned in Custom Made Sail Shade Structures above. Connect your sail with your relevant tensioners, and secure tightly. The more tension applied to the sail will ensure that it has less movement and will maximize the longevity of the product.

Congratulations! Your DIY Shade Structure is Complete!